

(No Model.)

2 Sheets—Sheet 1.

J. E. WOODBRIDGE. SCREW CUTTING TOOL.

No. 414,357.

Patented Nov. 5, 1889.

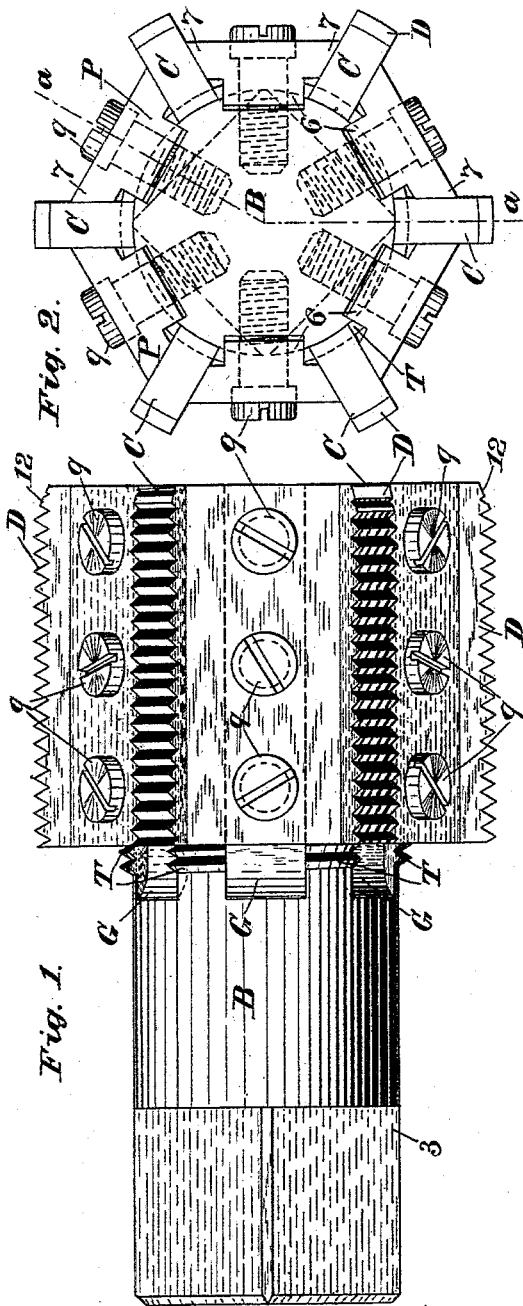

Fig. 2.

Fig. 1.

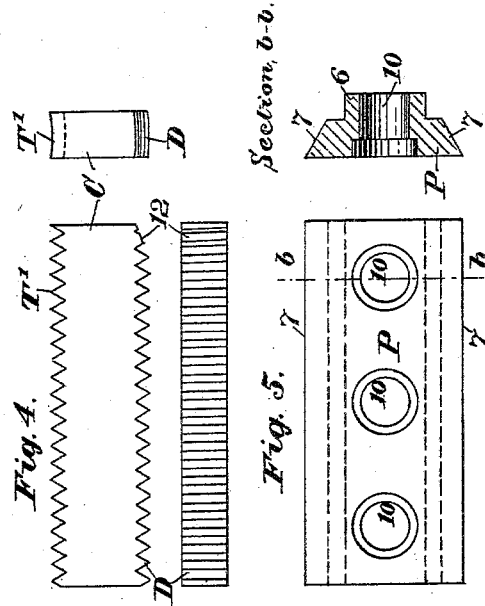

Fig. 4.

Section, b-b.

Fig. 5.

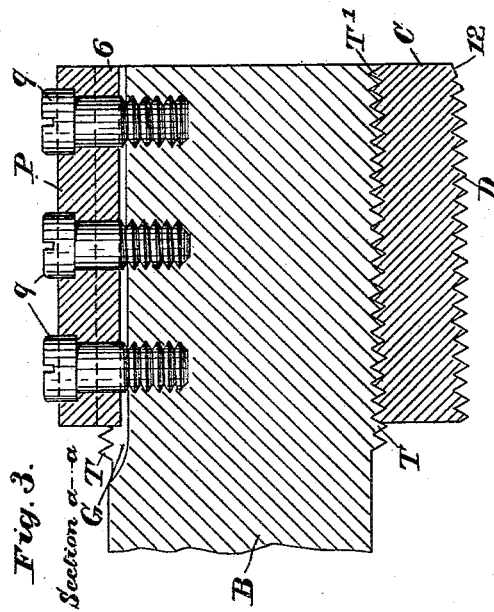

Fig. 3.

Inventor:
James E. Woodbridge,
by *F. H. Richards,*
Attorney.

Witnesses:

L. R. Keermann,
Geo. W. Drake

(No Model.)

2 Sheets—Sheet 2.

J. E. WOODBRIDGE.
SCREW CUTTING TOOL.

No. 414,357.

Patented Nov. 5, 1889.

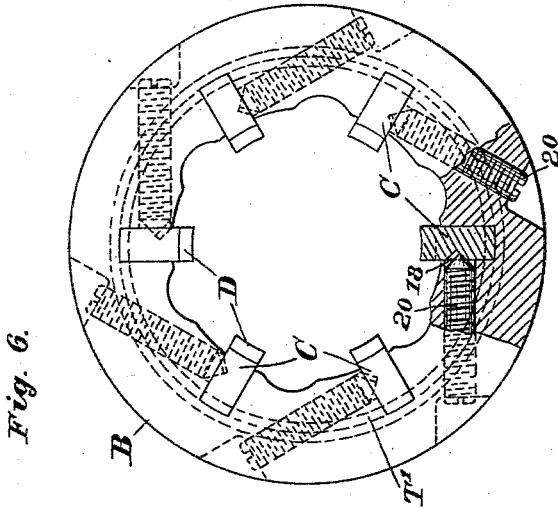

Fig. 6.

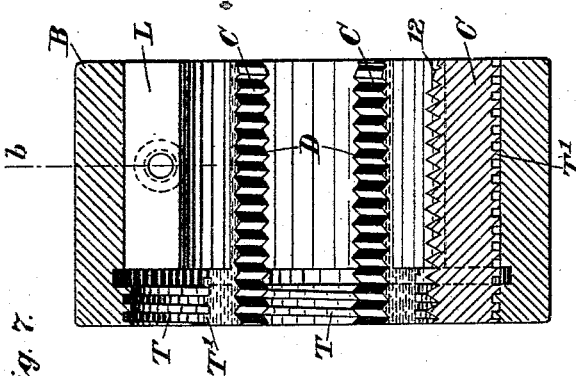

Fig. 7.

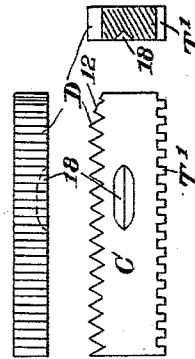

Fig. 8.

Witnesses:

L. L. Heermann.
Geo. W. Drake

Inventor:

James E. Woodbridge
by J. H. Richards
Attorney.

UNITED STATES PATENT OFFICE.

JAMES E. WOODBRIDGE, OF HARTFORD, CONNECTICUT, ASSIGNOR TO THE PRATT & WHITNEY COMPANY, OF SAME PLACE.

SCREW-CUTTING TOOL.

SPECIFICATION forming part of Letters Patent No. 414,357, dated November 5, 1889.

Application filed February 3, 1888. Renewed October 5, 1888. Serial No. 287,337. (No model.)

To all whom it may concern:

Be it known that I, JAMES E. WOODBRIDGE, a citizen of the United States, residing at Hartford, in the county of Hartford and State of Connecticut, have invented certain new and useful Improvements in Screw-Cutting Tools, of which the following is a specification.

This invention relates to taps and dies for cutting the screw-threads of bolts and nuts, and especially of pipe-fittings.

The chief objects of the invention are to furnish an improved tool of that class in which the renewable chasers shall be so attached to the tool-body that the same may be readily set forward from time to time as the chaser-point is dulled and reground, and in which the said chasers shall be substantially alike, so that one chaser may be substituted for either one of a set of them, all as herein-after more fully set forth.

In the drawings accompanying and forming a part of this specification, Figure 1 is a side elevation of a screw-cutting tap embodying my improvements. Fig. 2 is an end elevation of the same drawn in projection with Fig. 1. Fig. 3 is a longitudinal section in line *aa*, Fig. 2. Fig. 4 shows one of the chasers in three views, which are drawn in projection with each other. Fig. 5 is a detail showing one of the chaser-clamping plates. Fig. 6 is a front or end view of a screw-cutting die embodying my present improvements, a part being shown broken away the better to exhibit the preferred construction of certain details. Fig. 7 is a longitudinal section through the die. Fig. 8 is a detail showing in three views one of the chasers in a form slightly modified from that shown in Fig. 4.

Similar characters designate like parts in all figures.

My present improvements being in the main equally applicable to both taps and dies, I will describe these adaptations thereof in the order named.

In Figs. 1 to 5, inclusive, B designates the body of the tap, having some means—as, for instance, a suitable stem or the squared portion 3—whereby power may be applied to turn the tool. The opposite or forward end

of said body B has formed thereon guide-notches T, which may normally (except for certain grooves cut therein) extend around the said body and for some distance longitudinally thereof.

The chasers C have the usual cutting-teeth D, and are severally provided with corresponding guide-notches T', and are set at proper circumferential intervals on the aforesaid tool-body in engagement with said notches T. For holding the series of chasers in place I prefer the following-described device: Between the several chaser-seats there are formed in the body B a series of grooves G G, for receiving the clamp-plates P. Each plate P has a tenon, rib, or tongue 6, fitting into said groove G, and edges 7, formed of such shape as required to properly bear against the chasers. The plates P are held in place by ordinary screws 9, which pass through holes 10 in the plates and are tapped into the body B, as well shown in Fig. 3. Each plate being drawn down between adjacent chasers, each chaser is thus held between two plates, and since the plates are wholly removable from the body B, together with the chasers, of course there is no impediment to the cutting of the guide-notches T. If the chasers were inserted in grooves formed in the body B, (not shown,) such an impediment would obviously in some cases exist, especially if the grooves were as long as the chasers themselves and if the said notches T were in the bottom of said grooves.

Another feature of my invention relates to the construction and arrangement of the respective series of guide-notches on the tool-body, whereby the respective notches in each series of notches are located on a spiral line around the said body, which line is of a pitch corresponding to the thread-cutting teeth D. By this means the said notches may be sections of a screw-thread of the said pitch, and this guide-thread (owing also to the construction described of the chaser-holding devices) may be formed in a screw-cutting lathe in the usual well-known manner. By means of this construction, whenever it is desired to advance (or withdraw) all of the chasers by a less distance than the space of one cutting-

tooth, all of the chasers may be carried around in the proper direction to the next slot and reset on the corresponding notches.

In renewing any chaser of the series the new one is simply substituted for the old one, after which the usual cutting ends 12 of the whole series are reground to have the proper corresponding positions on the tool. As these beveled parts 12 become worn the chasers are set forward on their seats by one thread or notch and all reground to preserve their proper working positions, and whenever any one chaser breaks away at the point, as they sometimes will, such chaser is set forward and reground to correspond with the other chasers.

One advantage of the tap shown herein is its adaptability for being passed entirely through the piece being threaded, and in some kinds of work this is an important feature. The guide-notches which engage with those of the chaser being on the body of the tool itself and the clamps or other equivalent means for holding the chasers in place being entirely within the circle of the cutting-teeth, there is no obstacle to the tap being passed through a piece, as above stated.

In Figs. 6, 7, and 8 my improvements are shown embodied in a screw-cutting die. In this form of tool the die body or collet B has formed therein a series of longitudinal slots L, Fig. 7, for receiving the chasers C. Rearward of said slots (at left hand in Fig. 7) the guide-thread T is formed, which in this instance is shown as a "square" thread and continued around the tool-body. The chasers lying in slots L extend over said guide notches or thread and have corresponding notches T' engaged therewith. For retaining the chasers in place the chasers each have a groove 18, into which the point of screw 20 projects after a well-known manner. The operation of the chasers in this die is substantially the same as in the tap above described, and the chasers are renewed and set in place in a similar manner, and by suitable care in constructing the tools, and especially the form and size of the guide-notches, the same chasers may be adapted for use in either the tap or the die.

The specific improvements which are shown in Figs. 6, 7, and 8, and which are not shown in Figs. 1 to 5, inclusive, are not by me claimed herein, but are claimed in another application, Serial No. 298,344, filed February 1, 1889.

Having thus described my invention, I claim—

1. In a screw-cutting tool, the combination of

a chaser-holder having thereon guide-notches adapted to engage with chasers set thereon lengthwise to the axis of said holder, and a series of chasers which on one side and longitudinally thereof have screw-cutting teeth, and which on another side and longitudinally thereof have guide-notches engaging with the notches of said holder, said cutting-teeth and guide-notches being of corresponding pitch, all substantially as described.

2. In a screw-cutting tool, the combination of a chaser-holder having thereon guide-notches adapted to engage with chasers set thereon lengthwise to the axis of said holder, and a series of chasers which on one side and longitudinally thereof have screw-cutting teeth, and which on the opposite side and longitudinally thereof have guide-notches engaging those of said holder, said cutting-teeth and guide-notches being of corresponding pitch, all substantially as described.

3. The improved screw-cutting tap herein described, it consisting of a stem or body having circumferentially spirally-distributed guide-notches on which to seat the chasers, notched screw-cutting chasers seated on said body with their notches in engagement with said guide-notches, and means, substantially as described, for holding said chasers in place, substantially as described.

4. The combination, with the body B, having thread T and grooves G, of the chasers C and the clamp-plates P, fitting into said grooves and bearing on said chasers, substantially as described.

5. The improved chaser herein described for a screw-cutting tool, it consisting in a chaser which has thread-cutting teeth on one side and longitudinally thereof, and which on another side and longitudinally thereof has guide-notches of a corresponding pitch and adapted to engage with other guide-notches on the body of said tool, substantially as described.

6. The improved chaser herein described for a screw-cutting tool, it consisting in a chaser which has thread-cutting teeth on one side and longitudinally thereof, and which on another side and longitudinally thereof has guide-notches of a corresponding pitch and constructed to engage with other guide-notches circumferentially spirally distributed on the body of said tool, substantially as described.

JAMES E. WOODBRIDGE.

Witnesses:

PHILETUS C. LATHROP,
GEO. M. BOND.